

# OV12D 12-megapixel product brief



## 12MP Image Sensor Provides Premium Video with HDR and Excellent Ultra Wide Angle Photo Performance



available in  
a lead-free  
package

OmniVision's OV12D is a 12MP sensor that offers the unprecedented combination of a large 1/2.43" optical format, on-chip 4-cell remosaic color filter, high speed phase-detect autofocus (PDAF) and extra pixels for 4K2K video electronic image stabilization (EIS). This 1.4 micron image sensor has selective conversion gain (SCG) for the optimum SNR under both dark and bright lighting conditions. As a result, the OV12D simultaneously provides professional quality video, especially for low light conditions, and ultra wide angle photos in smartphones with multicamera configurations. This unique combination of features also makes the sensor ideal for high end front-facing selfie cameras.

SCG allows the pixel conversion gain to be dynamically switched between low and high, depending on the scene being captured. In combination with the OV12D's other features, including PureCel®Plus pixel technology for

reduced cross talk and maximum quantum efficiency in low light, secondary smartphone cameras equipped with the OV12D are able to capture the industry's highest quality video and ultra wide angle photos.

The OV12D is a native 16:9 aspect ratio image sensor that uses a 4-cell color filter pattern. It has on chip 4-cell to Bayer remosaic, in order to provide 4K video at 60 fps with 20% additional pixels for EIS. In a 4-cell binned mode, it can output an impressive 3MP/1080p resolution with 20% additional pixels for EIS video and images at four times the sensitivity. This sensor also supports both CPHY and DPHY interfaces, and can output 12MP 16:9 captures at 60 fps, 4K video at 60 fps and 1080p video at 240 fps.

Find out more at [www.ovt.com](http://www.ovt.com).



OmniVision.

## Applications

- Smart Phones
- Video Conferencing
- PC Multimedia

## Product Features

- automatic black level calibration (ABL)
- programmable controls for:
  - frame rate
  - mirror and flip
  - binning
  - cropping
  - windowing
- support for dynamic defect pixel cancellation (DPC)
- supports output formats:
  - 10-bit RGB 4-cell pattern Bayer RAW
- supports horizontal and vertical subsampling
- supports typical images sizes:
  - 4608 x 2592
  - 3840 x 2160
  - 2304 x 1296
  - 1920 x 1080
  - 1280 x 720
- standard serial SCCB interface
- up to 4-lane MIPI TX interface with speed up to 2.5 Gbps/lane
- embedded 8k bits of one-time programmable (OTP) memory (4k bits reserved for customer use)
- 2/3 trio C-PHY interface, up to 1.6 Gbps/trio
- 4-cell support:
  - 4-cell binning
  - 4-cell full
- on-chip 4-cell to Bayer converter
- supports type-2 4C HS PDAF
- three on-chip phase lock loops (PLLs)
- sequential multi-frame HDR
- 3MP 10-bit 3-exposure 4C HDR output after tone mapping
- programmable I/O drive capability
- built-in temperature sensor
- typical module size: 8.5 x 8.5 x -5.1 mm

# OV12D2Q



## Ordering Information

- OV12D2Q-GA5A (color, chip probing, 150 μm backgrinding, reconstructed wafer with good die)

## Technical Specifications

- active array size: 4608 x 2592
- maximum image transfer rate:
  - 4608 x 2592: 60 fps
- power supply:
  - core: 1.1V
  - analog: 2.8V
  - I/O: 1.8V
- power requirements:
  - active: 505 mW
  - standby: <10 μW
- temperature range:
  - operating: -30°C to +85°C junction temperature
  - stable: 0°C to +60°C junction temperature
- output formats:
  - 10-bit RGB 4-cell pattern Bayer RAW
- lens size: 1/2.43"
- lens chief ray angle: 35.7° non-linear
- scan mode: progressive
- pixel size: 1.404 μm x 1.404 μm
- image area: 6514.56 μm x 3684.1 μm

## Functional Block Diagram

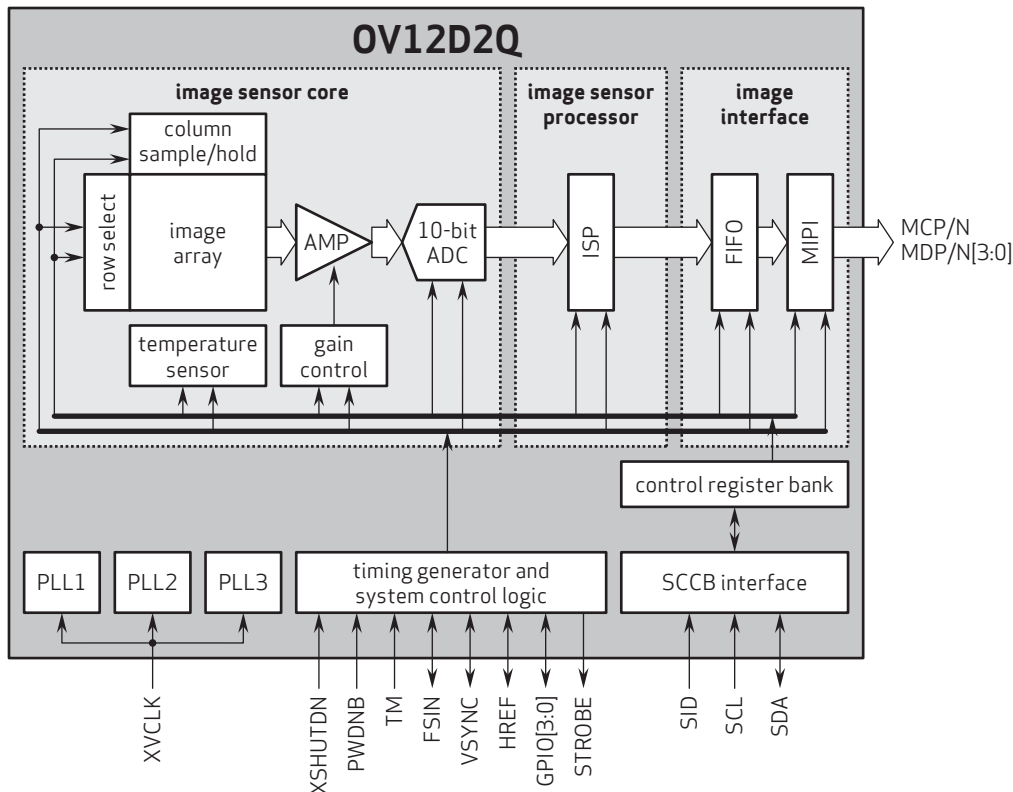

4275 Burton Drive  
Santa Clara, CA 95054  
USA

Tel: +1 408 567 3000  
Fax: +1 408 567 3001  
www.ovt.com

OmniVision reserves the right to make changes to their products or to discontinue any product or service without further notice. OmniVision, the OmniVision logo and PureCel are registered trademarks of OmniVision Technologies, Inc. All other trademarks are the property of their respective owners.



OmniVision