



OV05C10

5.2-megapixel product brief



16:10 Aspect Ratio, 5.2MP Resolution Image Sensor Designed for Laptops and IoT Devices

The OV05C10 image sensor features 5.2-megapixel (MP) resolution with 1.12 μm pixels and is specially developed for 16:10 aspect ratio notebooks, including mainstream and high-end laptops, tablets and IOT devices. The backside illumination (BSI) image sensor is based on OMNIVISION's PureCel®Plus technology for higher sensitivity, less noise and better overall image quality. It features two-exposure staggered HDR timing at 5.2MP and 60 frames per second (fps), allowing for improved image quality in bright or dark environments.

At 5.2MP resolution, the OV05C10 image sensor has ample pixels to support auto framing for video conferencing, which automatically adjusts the camera's field of view to keep the person speaking at the center of the image while cropping out distracting backgrounds. The OV05C10 also supports human presence detection (HPD), which increases the efficiency of artificial intelligence (AI) applications and extends the battery life of portable devices.

Find out more at www.ovt.com.



OV05C10

Ordering Information

- **OV05C10-A28A-001A-Z** (color, lead-free)
28-pin CSP, packed in tray without protective film
- **OV05C10-GA5A-001A-Z** (color, chip probing,
150 µm backgrinding, reconstructed wafer with good die)

Applications

- laptop PC
- PC multimedia
- cellular phones
- tablets

Technical Specifications

- **active array size:** 2888 x 1808
- **output interfaces:**
10-bit 2-lane MIPI TX
- **maximum image transfer rate:**
 - full size normal 2888 x 1808: 60 fps
 - full size HDR 2888 x 1808: 30 fps
- **output formats:** 10-bit RGB RAW /
8-bit RGB RAW for ULP
- **power supply:**
 - core: 1.2V
 - analog: 2.8V (2.7 ~ 3.0V)
 - I/O: 1.14 ~ 1.32V, 1.62 ~ 1.98V
- **lens size:** 1/4.7"
- **lens chief ray angle:** 34.68° non-linear
- **scan mode:** progressive
- **temperature range:**
 - operating: -30°C to +85°C
junction temperature
 - stable: 0°C to +60°C
junction temperature
- **shutter:** rolling
- **pixel size:** 1.116 µm x 1.116 µm
- **image area:**
3223.008 µm x 2017.728 µm

Product Features

- supports image sizes:
 - 5MP (2888 x 1808)
 - 2K (2560 x 1440)
 - 1080p (1920 x 1080)
 - 720p (1280 x 720), and more
- programmable controls for:
 - frame rate
 - mirror and flip
 - cropping
 - windowing
- supports output formats:
10-bit RGB RAW
- two on-chip phase lock loops (PLLs)
- two-wire serial bus control (SCCB)
- 1024 bytes of embedded one-time programmable (OTP) memory
- image quality control:
 - static defect pixel correction
 - automatic black level calibration
- supports multi-camera synchronization function
- slave SCCB interface for sensor setting, with max 400kHz speed (supports 1MHz with 12MHz ECLK)

Functional Block Diagram

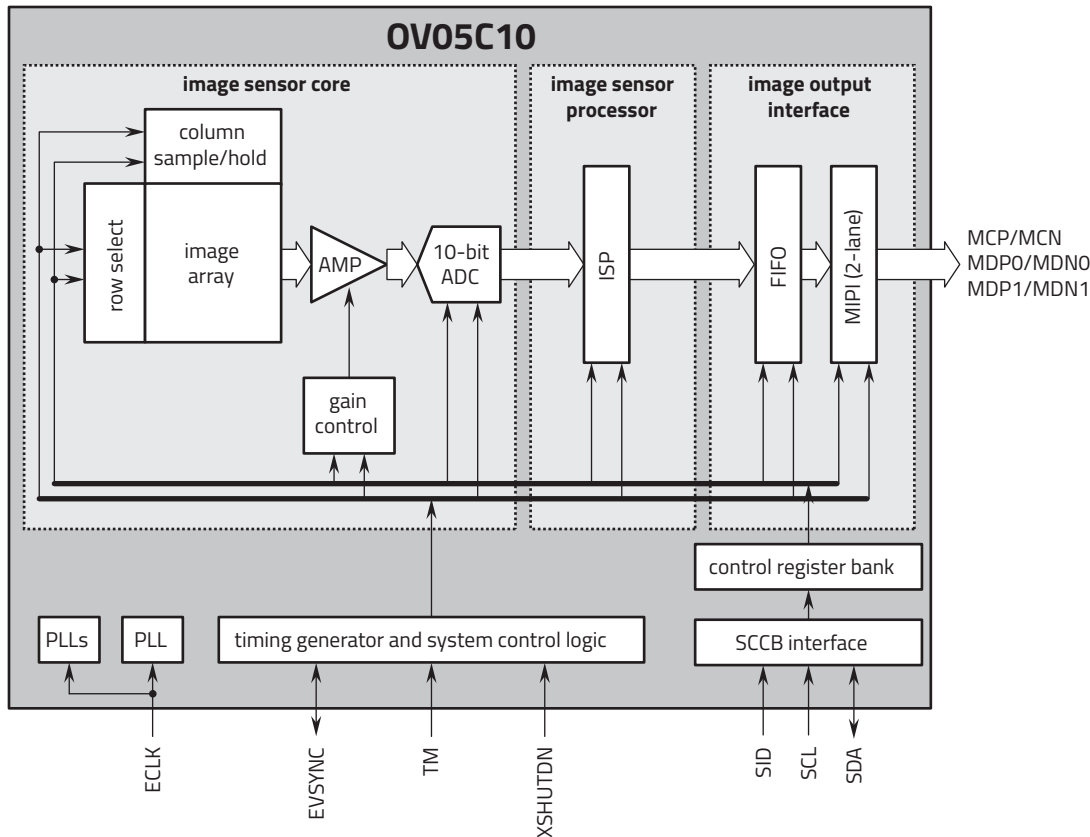

Version 1.0, November 2023