

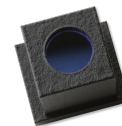

# OVM7251

## VGA product brief



### Compact Global Shutter Camera Module for Near-Infrared Mobile Facial Authentication, AR/VR Eye Tracking and Machine Vision

OMNIVISION's OVM7251 CameraCubeChip® module is built on the 3  $\mu\text{m}$  OmniPixel®3-GS global shutter architecture. The OVM7251 offers designers a small form factor, low power consumption and a cost effective 640 x 480 VGA resolution camera module. The module provides low power consumption via multiple standby modes and faster global shutter capture and processing during active mode. Additionally, it is available in an 850 nm version for AR/VR eye tracking, and a 940 nm version for machine vision and 3D sensing in mobile facial authentication.

The OVM7251's sleep current consumption is only at 5  $\mu\text{A}$ . During active mode, the module's global shutter enables fast image capture. This arrangement can result in extended

battery life for a broad range of applications, such as head-mounted displays for AR/VR, facial authentication in smart phones, and machine vision for factory automation, barcode readers and robot vacuum cleaners.

OMNIVISION's CameraCubeChip® modules reduce design time by integrating the image sensors, processor and lenses in a miniature wafer-level, reflowable chip-scale package. The OVM7251 module is available now for sampling and volume production, along with an evaluation kit.

Find out more at [www.ovt.com](http://www.ovt.com).



# OVM7251

## Ordering Information

- **OVM7251-RAIA** (b&w, lead-free)  
CameraCubeChip® with black coating, 850 nm short focus
- **OVM7251-RAIA-R1** (b&w, lead-free)  
CameraCubeChip® with black coating, 940 nm long focus

## Applications

- eye tracking
- security and surveillance
- wearable devices
- toys and games

## Product Features

- 3  $\mu\text{m}$  x 3  $\mu\text{m}$  pixel with OmniPixel®3-GS technology
- supports horizontal and vertical 2:1 and 4:1 monochrome subsampling
- automatic black level calibration (ABLC)
- supports 2x2 monochrome binning
- programmable controls for:
  - frame rate
  - mirror and flip
  - cropping
  - windowing
- one-lane MIPI serial output interface
- one-lane LVDS serial output interface
- support output formats: 8/10-bit RAW
- embedded 256 bits of one-time programmable (OTP) memory for part identification
- support for image sizes:
  - 640 x 480
  - 320 x 240
  - 160 x 120
- two on-chip phase lock loops (PLLs)
- fast mode switching
- built-in 1.5V regulator for core
- PWM
- built-in strobe control

## Technical Specifications

- **active array size:** 640 x 480
- **temperature range:**
  - operating:  $-30^{\circ}\text{C}$  to  $+70^{\circ}\text{C}$  junction temperature
  - stable image:  $0^{\circ}\text{C}$  to  $+50^{\circ}\text{C}$  junction temperature
- **maximum image transfer rate:**
  - 640 x 480: 120 fps
- **power supply:**
  - analog: 2.8V (nominal)
  - core: 1.5V (optional)
  - I/O: 1.8V (nominal)
- **output formats:** 10-bit RAW BW
- **optical format:** 1/7.5"
- **power requirements:**
  - active: 119 mW @ 120 fps, VGA output
  - standby: 15  $\mu\text{A}$  for AVDD, 40  $\mu\text{A}$  for DOVDD without input clock, 700  $\mu\text{A}$  for DOVDD with input clock
  - XSHUTDOWN: 5  $\mu\text{A}$  for AVDD, 5  $\mu\text{A}$  for DOVDD
- **diagonal field of view (FOV):**
  - RAIA:  $80^{\circ}$
  - RAIA-R1:  $83^{\circ}$
- **f no.:** 2.2
- **focal length:**
  - RAIA: 1.837 mm
  - RAIA-R1: 1.842 mm
- **scan mode:** progressive
- **output interface:** 1-lane MIPI/LVDS serial output
- **pixel size:** 3  $\mu\text{m}$  x 3  $\mu\text{m}$
- **image area:** 1968  $\mu\text{m}$  x 1488  $\mu\text{m}$

## Functional Block Diagram

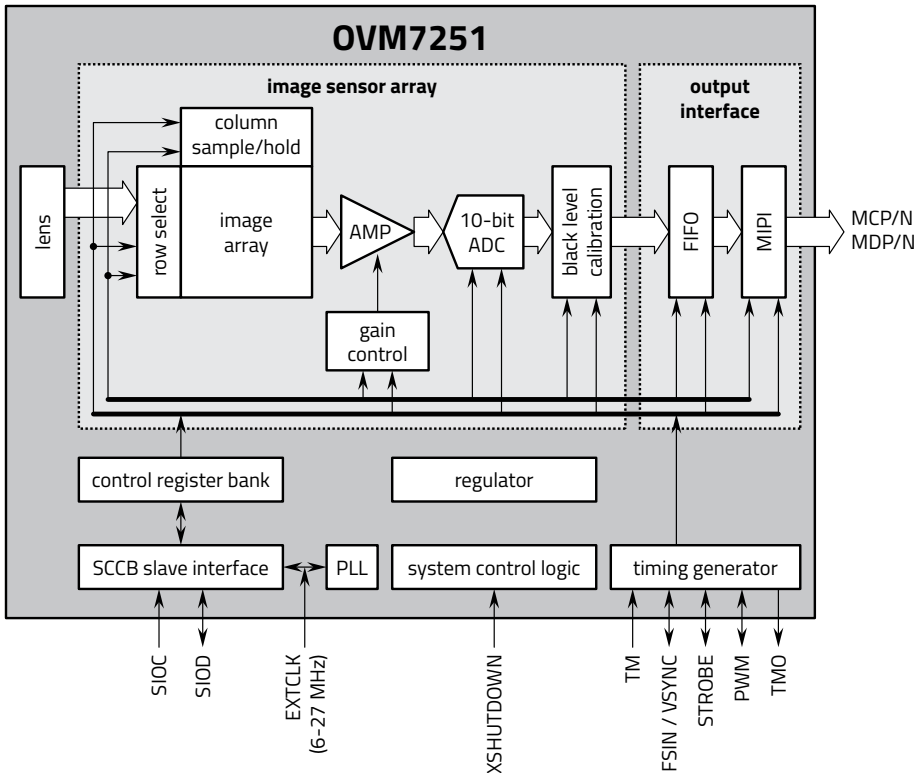

Version 1.4, August 2024

4275 Burton Drive  
Santa Clara, CA 95054  
USA

Tel: + 1 408 567 3000  
Fax: + 1 408 567 3001  
www.ovt.com

OMNIVISION reserves the right to make changes to their products or to discontinue any product or service without further notice. OMNIVISION, the OMNIVISION logo, CameraCubeChip, and OmniPixel are registered trademarks of OmniVision Technologies, Inc. All other trademarks are the property of their respective owners.

 **OMNIVISION®**