

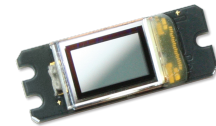

# OVP2200+OVP921

## 720p product brief



### 720p High Definition LCOS Display for Wearable Electronics

OMNIVISION's new ultra-compact and low-power OVP2200 liquid crystal on silicon (LCOS) solution delivers best-in-class 720p high-definition (HD) video at 60 frames per second (fps) to displays in next-generation wearable electronics. The single-chip OVP2200 is supported by the OVP921 companion chip, which provides image processing and further simplifies system design.

The OVP2200 is a single panel, color field sequential device based on a 4.5-micron pixel with a native resolution of 1280 x 720 pixels and a diagonal measurement of 0.26-inch. It uses all-digital technology to produce clear, stable images. The OVP2200's ultra-compact form factor and low-power consumption make it an ideal LCOS solution for applications ranging from wearable smartphone displays to sports and medical cameras.

The OVP921 provides enhanced system performance without the need for an external image processor. The OVP921 has built-in keystone correction, frame rate conversion, video input scaling, an LED controller, and an embedded 8051 microcontroller (MCU). Additionally, the OVP921 can accept inputs via 24-bit RGB, MIPI or USB.

The HD resolution enabled by the OVP2200 and the OVP921, combined with solid-state light sources, allows customers to create low-cost, compact projection systems with high optical output. These systems are capable of projecting images and video at more than 20 Lumens with LED power at 1.8W with a well-designed optical engine.

Find out more at [www.ovt.com](http://www.ovt.com).



# OVP2200+OVP921

## Ordering Information

- OVP2200-MAAA-TA (lead-free) 35-pin PCB
- OVP2200-MADA-TB (lead-free) 30-pin FPCA without compensator
- OVP0921-B44G (lead-free) 144-pin BGA package

## Applications

- compact front projectors
- high definition rear projection TVs

## Technical Specifications

### OVP2200

- **power supply:**
  - core: 1.5V  $\pm$ 5% typical
  - I/O: 1.5V  $\pm$ 5% typical
  - pixel array: 5.5V  $\pm$ 5% typical
- **power requirements:**
  - active: 200 mW
  - standby: 1.5 mW
- **temperature range:**
  - operating: +10°C to +70°C
- **active area:** 5.832 mm x 3.240 mm
- **native resolution:** 1280 x 720
- **native device diagonal:** 0.26 in
- **pixel pitch:** 4.5  $\mu$ m
- **package dimensions:**
  - PCB: 17.5 x 6.6 x 3.2 mm
  - FPCA: 37.57 x 8.9 x 2.12 mm

### OVP921 (driver)

- **power supply:**
  - core: 1.2V
  - I/O: 1.8V / 3.3V
- **power requirements:**
  - 1.2V: 210 mW (at max resolution)
  - 3.3V: 120 mW
- **temperature range:** 0°C to +70°C
- **package dimensions:** 9 mm x 9 mm

## Product Features

### OVP2200

- standard 100% digital CMOS technology
- no spacers in active area
- digital interface
- high aperture ratio
- insensitive to photo-induced carrier generation
- designed for color field sequential operation
- horizontal alignment of 16 pixels
- vertical alignment of 16 lines

### OVP921 (driver)

- OVP921 will drive OMNIVISION's color field sequential LCOS panels with resolutions up to 1280 x 720
- includes two video inputs:
  - single pixel 24-bit RGB
  - 2 channel MIPI DSI receiver 24-bit packed RGB888
- includes dual internal PLL clock generation
- outputs enable/disable control signals to external solid state light sources
- supports horizontal and vertical flipping and programmable sync polarities
- supports several video scaling functions
- converts incoming video to fixed resolution of LCOS panel
- $\pm$ 15 degree vertical keystone correction
- includes on-chip 8051 microcontroller with 32 KB program space and 256 bytes RAM

## Functional Block Diagram

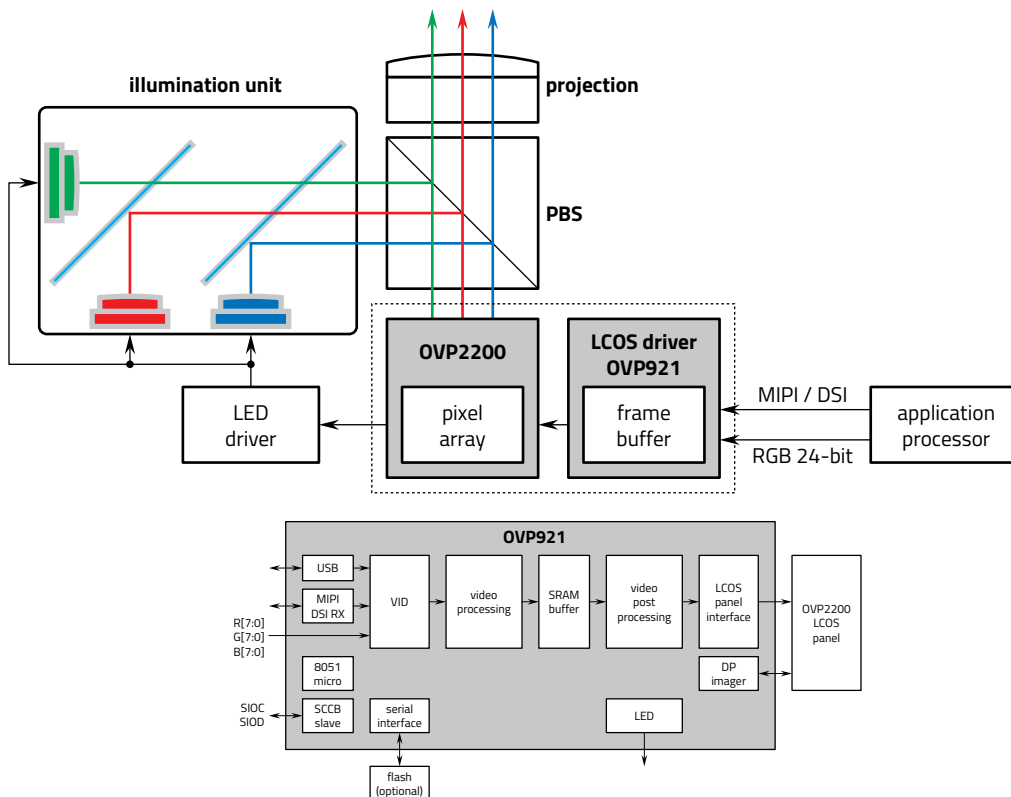

Version 1.6, September 2024

4275 Burton Drive  
Santa Clara, CA 95054  
USA

Tel: + 1 408 567 3000  
Fax: + 1 408 567 3001  
www.ovt.com

OMNIVISION reserves the right to make changes to their products or to discontinue any product or service without further notice. OMNIVISION, the OMNIVISION logo, PureCel, and Nixel are registered trademarks of OmniVision Technologies, Inc. a-CSP and Deep Well are trademarks of OmniVision Technologies, Inc. All other trademarks are the property of their respective owners.

OMNIVISION®