



OV9734

720p product brief



OMNIVISION's Small 720p High Definition Sensor for Next-Generation Notebooks and Mobile Devices

The OV9734 is an ultra-compact and power efficient CameraChip™ image sensor designed for slim notebooks, tablets, handsets, and other devices that require a thin bezel. Built on OMNIVISION's PureCel® technology, the OV9734 CameraChip™ delivers premium quality images and video, while consuming significantly less power than previous generation image sensors.

OMNIVISION's 1/9-inch OV9734 is capable of capturing crisp 720p HD video at 30 frames per second (fps) or VGA video at 45 fps, while consuming approximately 25 percent less power than the previous generation 720p sensor. Additionally, the OV9734 meets the video quality specifications for popular video conferencing platforms.

To fit ultra-thin bezel devices, the OV9734 comes in a compact package that can meet 2.5 mm z-height and is 47 percent smaller in y-dimension compared to the previous generation 720p sensor.

The OV9234, a black and white version of the OV9734, is also available as a dedicated IR camera solution for facial recognition and other biometric applications. Both sensors are available in CSP and COB packaging.

Find out more at www.ovt.com.



OV9734

Ordering Information

- **OV09734-H16A** (color, lead-free)
16-pin CSP
- **OV09234-H16A** (B&W, lead-free)
16-pin CSP
- **OV09734-GA5A** (color, chip probing,
150 µm backgrinding,
reconstructed wafer with good die)
- **OV09234-GA5A** (B&W, chip probing,
150 µm backgrinding,
reconstructed wafer with good die)

Applications

- smartphones
- digital still cameras
- PC multimedia
- toys
- tablets

Technical Specifications

- **active array size:** 1280 x 720
- **temperature range:**
 - operating: -30°C to +85°C
 - junction temperature
 - stable: 0°C to +50°C
 - junction temperature
- **maximum image transfer rate:**
1280 x 720: 30 fps
- **power supply:**
 - analog: 2.6V ~ 3.0V (2.8V normal)
 - core: 1.2VDC ±5%
 - I/O: 1.8V
- **power requirements:**
 - active: 69 mW
 - XSHUTDN: 0.9 µW
- **output formats:** 10-bit RGB RAW
- **lens size:** 1/9"
- **lens chief ray angle:** 32.1°
- **scan mode:** progressive
- **pixel size:** 1.4 µm x 1.4 µm
- **image area:**
1819.58 µm x 1033.34 µm

Product Features

- support for image sizes:
 - full size (1280 x 720)
 - VGA (640 x 480)
 - 2x2 RGB binning (640 x 360)
 - 2x2 B&W binning (640 x 360)
- support for horizontal and vertical sub-sampling
- support for output formats:
RAW output with 1-lane MIPI
- support for black level calibration (ABLCL)
- capable of maintaining register values at software power down
- defect pixel correction (DPC)
- support for black sun cancellation
- programmable controls for:
 - frame rate
 - mirror and flip
 - gain / exposure
 - windowing
- standard SCCB interface
- on-chip phase lock loop (PLL)
- GPIO tri-state configurability and programmable polarity

Functional Block Diagram

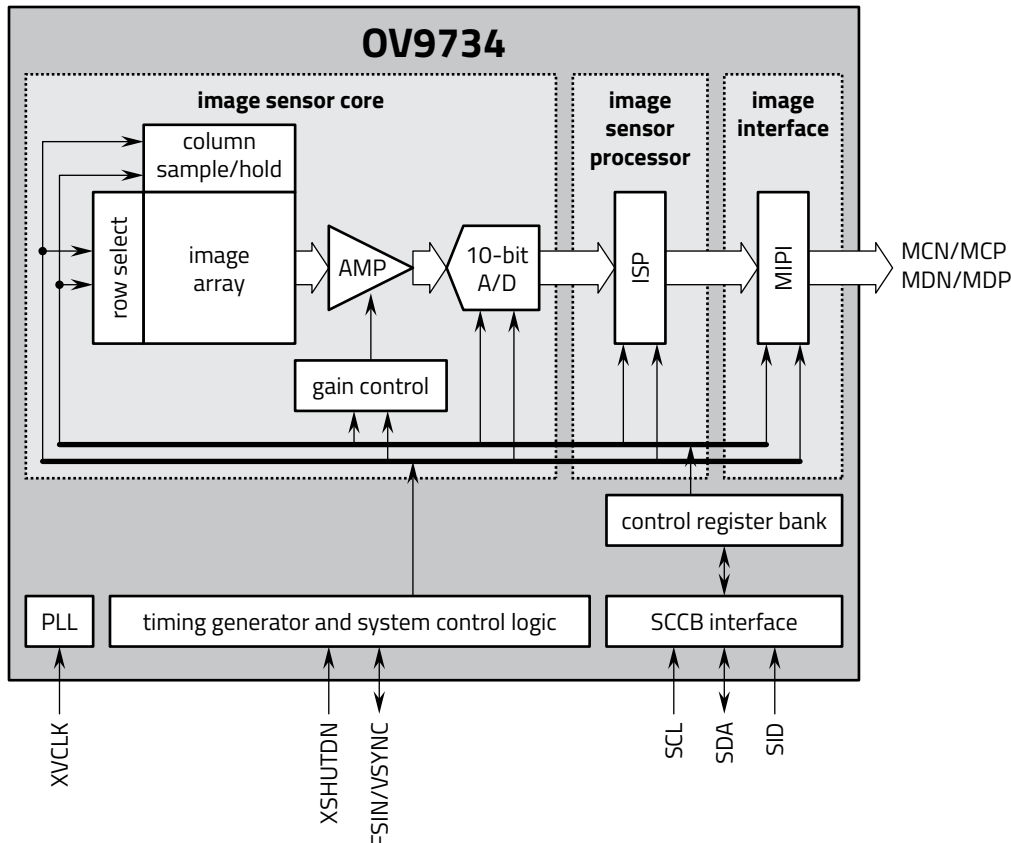

Version 1.1, December 2024

4275 Burton Drive
Santa Clara, CA 95054
USA

Tel: + 1 408 567 3000
Fax: + 1 408 567 3001
www.ovt.com

OMNIVISION reserves the right to make changes to their products or to discontinue any product or service without further notice. OMNIVISION, the OMNIVISION logo, and PureCel are registered trademarks of OmniVision Technologies, Inc. CameraChip is a trademark of OmniVision Technologies, Inc. All other trademarks are the property of their respective owners.

 **OMNIVISION®**

